

KS / KSA / NK / NX / NXR

PLATE CLAMPS

USER OPERATING AND INSPECTION MANUAL



KS



KSA



NK



NX / NXR

Clamps compliant with ANSI B30.20

Before installing clamp, fill in the information below.

Model Number: _____

Serial Number: _____

Purchase Date: _____



GENERAL WARNING

Follow the instructions and warnings for inspecting, maintaining and operating this clamp. The use of any clamp presents some risk of personal injury or property damage. That risk is greatly increased if proper instruction and warnings are not followed. Before using this clamp, each user should become thoroughly familiar with all warnings, instructions and recommendations in this manual.

RETAIN THIS MANUAL FOR FUTURE REFERENCE AND USE.

Forward this manual to all users. Failure to operate equipment as directed in manual may cause serious injury or death



www.tractel.com

KS / KSA / NK / NX / NXR



PLATE CLAMPS

CONTENTS	Page
Total Plate Clamps Safety Symbols	3
General Warnings	4
Tractel Lifting Clamps	5
KS Description and Dimensions	6
KS Inspection of clamp before use	7
KS Trouble Shooting Chart	8
KSA Description and Dimensions	9
KSA Inspection of clamp before use	10
KSA Trouble Shooting Chart	11
NK Description and Dimensions	12
NK Inspection of clamp before use	13
NK Trouble Shooting Chart	14
NX / NXR Description and Dimensions	15
NX Inspection of clamp before use	16
NX Trouble Shooting Chart	17
KS / KSA / NK Use and Installation	18
KSA Applications	19
KS / KSA / NK Important Instructions	20
KS / NK Applications	21
NX / NXR Use and Installation	22
NX Important Instructions	23
NX Applications	24
General Maintenance & Labels	25
Service	26-27





TOPAL Plate Clamps Safety Symbols

Safety advice

Symbol	Code word	Meaning	Possible non-compliance consequence
	WARNING	IMMEDIATE or possibly imminent danger:	Fatal or serious injuries!
	CAUTION	possibly dangerous situation:	Minor injuries to persons!

Other advice

	NOTE	possibly dangerous situation:	Damage to equipment or its surroundings
	Instruction for (none)	documentation in writing (i.e. record keeping)	No recorded history

To ensure the on-going improvement of its products, Tractel® reserves the right, at any time, to apply any changes which it may deem useful to the clamps described in this manual. The Tractel® group companies and their authorized dealers will provide you, on request, with a complete documentation covering the full range of Tractel® products: Lifting and pulling equipment, worksite and façade access equipment (BMUs), safety devices for loads, electronic load indicators, etc. The Tractel® network also provides after-sales and periodic maintenance services.



GENERAL WARNING

- 1) Before installing and using this clamp, you must be familiar with the information contained in this manual and you must comply with the utilization and safety instructions given to ensure safe use of the clamp. A copy of this manual should be available to all clamp users. Additional copies can be provided on request.
- 2) Do not use the clamp if any of the labels on the clamp are damaged or illegible, or if any of the markings, as indicated at the end of this manual, are no longer legible. If a damaged information plate is observed, identical plates can be supplied on request and should be fastened to the clamp before continuing to use.
- 3) Make sure that any person to whom you have entrusted use of this clamp is familiar with the information contained in this manual and is able to satisfy the safety requirements involved by the purpose for which the clamp is used. This manual should be in the user's possession.
- 4) This clamp must only be used in compliance with the applicable safety standards and all Federal, state, local and provincial regulations concerning installation, use, maintenance and inspection of materials lifting.
- 5) For all professional purposes, this clamp must be placed under the responsibility of a qualified person who is familiar with the applicable regulations and who has the necessary authority to ensure application of these regulations by all users.
- 6) Any person using this clamp for the first time must check, in a risk-free environment, before applying the load, and on a limited lifting height, that he has fully understood all the requirements for safe, efficient operation of the clamp.
- 7) Setup and operation of the clamp must only be performed under conditions ensuring installer safety in compliance with the regulations applicable to the clamp category.
- 8) Each time, before using the clamp, visually check that the clamp are in good condition.
- 9) Tractel® shall not be held liable for use of this clamp in any setup configuration not described in this manual.
- 10) Any changes to the clamp not supervised by Tractel®, including removal of parts from the clamp, shall release Tractel® from any liability.
- 11) Any clamp assembly or disassembly not described in this manual, or any repair performed outside Tractel® supervision will release Tractel® from any liability, especially as may concern replacement of genuine parts by parts from another source.
- 12) Any alteration on the clamp aimed at modifying or repairing it outside Tractel® supervision will release -Tractel® from any liability subsequent to the modification or repair performed.
- 13) This clamp must never be used for any operations other than those described in this manual. The clamp should never be used with loads exceeding the rated load indicated on the clamp.
- 14) The clamp should never be used in an explosive atmosphere.
- 15) Never use this clamp for lifting or moving persons.
- 16) When it is necessary to lift a load using several units, a technical study by a qualified technician must first be carried out to ensure proper installation and operation in compliance with the technical study, in particular to ensure an even distribution of the load under appropriate conditions. Tractel® shall not be held liable for use of any Tractel® device in combination with other lifting devices of a different manufacturer.
- 17) The clamp must be attached to a fixed mast and to a structure which is sufficiently strong, consistent with the applicable safety coefficient, to stay within the rated load indicated in this manual. If several units are used, the strength of the structure and the anchor point must be consistent with the number of clamps used in accordance with their working load limit.
- 18) To ensure safe use of the clamp, it should be visually inspected and serviced regularly. Depending on the nature of the environment in which the clamp is used, check regularly for any signs of corrosion.
- 19) Never take position or circulate under the load. The area located under the load should be clearly marked out and barricaded.
- 20) Keeping the clamp in good condition is essential to safety and correct operation of the clamp. Any clamp showing any signs of damage must be immediately and definitively removed from use.
- 21) When the clamp is not used, it should be placed out of reach of all persons not authorized to use it.
- 22) The clamp should be inspected periodically by a Tractel® approved repair agent as indicated in this manual.
- 23) During use, the user must ensure that the clamp is constantly tensioned by the load and, in particular, that the clamp is not temporarily snagged by an obstacle when bringing a load down as this could result in rupture of the clamp or loss of the load when the load comes free from its obstacle.



Tractel® lifting clamps

Table 1

Model	Item Number	Weight lbs.	Weight kg	WLL lbs. (t)	WLL kg	Opening inches	Opening mm
KSA075 0-15	54768	3.3	1.5	1,650 (3/4)	750	0- 9/16	0-15
KSA1 0-20	54778	7.0	3.2	2,200 (1)	1,000	0- 3/4	0-20
KS075 0-15	50238	3.5	1.6	1,650 (3/4)	750	0- 9/16	0-15
KS1 0-20	50248	7.7	3.5	2,200 (1)	1,000	0- 3/4	0-20
KS2 0-25	50258	13.9	6.3	4,400(2)	2,000	0- 1	0-25
KS3 0-30	50268	26.6	12.1	6,600 (3)	3,000	0- 1 1/8	0-30
NK1 0-20	50288	8.8	4	3,300 (1.5)	1,500	0- 3/4	0-20
NK1 20-40	50298	12.8	5.8	3,300 (1.5)	1,500	3/4 - 1 1/2	20-40
NK1 40-60	50308	13.2	6	3,300 (1.5)	1,500	1 5/8-2 5/16	40-60
NK2 0-30	50318	28.6	13	6,600 (3)	3,000	0- 1 1/8	0-30
NK2 30-60	50328	33.0	15	6,600 (3)	3,000	1 3/16- 2 5/16	30-60
NK2 60-90	50338	37.4	17	6,600 (3)	3,000	2 3/8- 3 1/2	60-90
NK3 0-40	50348	55.0	25	9,900 (4.5)	4,500	0- 1 1/2	0-40
NK3 40-80	50358	57.2	26	9,900 (4.5)	4,500	1 5/8- 3	40-80
NK3 80-120	50368	59.4	27	9,900 (4.5)	4,500	3 3/16-4 5/8	80-120
NK5 0-50	50378	93.1	42.3	16,500 (7.5)	7,500	0-2	0-50
NK5 50-100	50388	110.0	50	16,500 (7.5)	7,500	2-4	50-100
NK5 100-150	50398	132.0	60	16,500 (7.5)	7,500	4-6	100-150
NK05 0-20	50408	9.9	4.5	1,100 (.5)	500	0- 3/4	0-20
NX05 0-20	50408	9.9	4.5	1,100 (.05)	500	0- 3/4	0-20
NX1.5 0-30	50418	24.2	11	3,300 (1.5)	1,500	0- 1 3/16	0-30
NXR05 0-100	50428	13.2	6	1,100 (.05)	500	0-4	0-100
NXR05 20-120	50438	12.8	5.8	1,100 (.05)	500	3/4 - 4 1/4	20-120
NXR05 40-140	50448	13.2	6	1,100 (.05)	500	1 5/8 - 5 1/2	40-140



KS

Multiposition Plate Clamps

Description

Clamps fitted with a spring mechanism for a permanent contact of the cam into the piece to be lifted. The locking lever does not stick out so that the

clamp may be used on the bare ground. The chain enables the revolving and makes the clamp's positioning easier. The cam is designed to mark only one side of the load.

KS Plate Clamp

Table 2

Ref.	Item Number	WLL lbs.(t)		Opening		A	B	C	D	E	F	G	Ring Dia	J	K	L	Chain Dia	Weight
		kg.	min	max	ln/mm													
KS075 0-15	50238	1,650 (3/4)	0	9/16	11 13/16	5	3 3/16	1 3/4	1 1/2	3 1/8	1 9/16	3/8	1/2	1 5/16	2 1/16	1/4	3.5	
		750	0	15	300	129	97	45	39	80	40	10	12	34	53	6	1.6	
KS1 0-20	50248	2,200 (1)	0	3/4	16 3/4	6 13/16	5	6 3/8	1 15/16	4 5/16	2 3/8	1/2	5/8	1 11/16	2 5/8	9/32	7.7	
		1,000	0	20	426	173	128	60	49	110	60	13	16	43	67	7	3.5	
KS2 0-25	50258	4,400(2)	0	1	19 1/16	8 9/16	6 5/16	2 15/16	2 7/16	4 5/16	2 3/8	5/8	3/4	1 7/8	3 1/8	5/16	13.9	
		2,000	0	25	485	218	161	75	62	110	60	16	19	47	79	8	6.3	
KS3 0-30	50268	6,600 (3)	0	1 1/8	23 7/16	10 1/4	8 1/16	3 11/16	3 3/8	5 5/16	2 15/16	11/16	1 1/16	2 1/4	3 3/4	13/32	26.6	
		3,000	0	30	595	260	205	94	85	135	75	18	28	58	96	10	12.1	

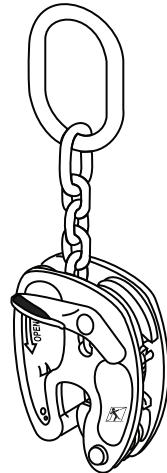
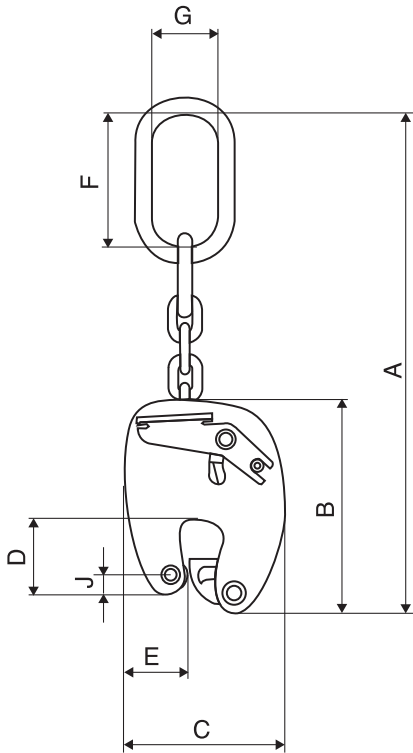

KS075 model

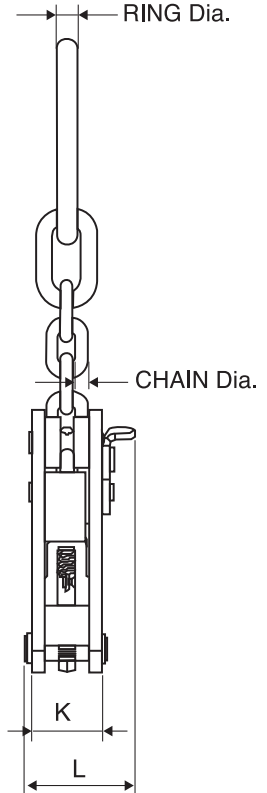

KS

Trouble shooting chart

Item	Trouble	Cause	Solution	Remarks	Action
1	The clamp does not close freely.	The springs are damaged or missing. The cocking lever is deformed. The clip was sticking.	Yes	Check carefully that no other component of that lever is bent and rubbing in the clamp.	Return to a Tractel® authorized repair center
2	Wear of the cam teeth, or the cam shaft	It's normal to wear the teeth of the cam. The toothed cam must penetrate the material of the load being lifted.	Yes	The cam is a critical component to monitor. Always replace the cam shaft along with the cam.	Return to a Tractel® authorized repair center
3	Chain Wear	This is normal wear mainly related to movement of the plate	Yes	All chain products should have an annual inspection.	Return to a Tractel® authorized repair center
4	Deformation of a component.	Very rare	Yes	The cam and cam shaft are critical components to be monitored.	Return to a Tractel® authorized repair center for inspection
5	The chain is broken or the cam is dislodged	Clamp has been overloaded	No	Such a rupture would only occur in case of overload.	Clamp to be destroyed and replaced
6	The cam is not in contact with the stop (for clamps that have a minimum opening of 0)	The springs are damaged or missing. The cocking lever is deformed.	Yes	Check carefully that no other component is damaged or the lever is bent and rubbing the clamp.	Return to a Tractel® authorized repair center for inspection
		The clamp is deformed	NO	Such deformation occurs only when overloaded.	Clamp to be destroyed and replaced
7	Clamp body deformed	Such deformation occurs only when overloaded	NO	Such deformation occurs only when overloaded.	Clamp to be destroyed and replaced

Whatever the diagnosis, always plan to loosen up the clamp before return to service



KSA

Plate Clamps with Ring

Description

Clamps fitted with a spring mechanism for a permanent contact of the cam onto the piece to be lifted.

The locking lever does not stick out so that it is unlikely to get damaged. The cam is designed to mark only one side of the load.

KSA Plate Clamp

Table 3

Ref.	Item Number	WLL lbs. (t)	Opening		A*		B	C	D	E	F	G	H	I	J	K	L	Weight
			min	max	min	max												
		kg.	in./mm		in./mm		in./mm	in./mm	in./mm	in./mm	in./mm	in./mm	in./mm	in./mm	in./mm	in./mm	in./mm	lb./kg.
KSA075 0-15	54768	1650 (3/4)	0	9/16	9	10	5	3 13/16	1 3/4	1 1/2	2 3/4	2 3/16	1/4	19/32	1/2	1 5/16	2 1/16	3.3
		750	0	15	228	255	129	97	45	39	70	55	6	15	12	34	53	1.5
KSA1 0-20	54778	2200 (1)	0	3/4	9 11/16	11	6 13/16	5	2 3/8	1 15/16	2 3/4	2 1/2	5/16	19/32	5/8	1 11/16	2 5/8	7.0
		1,000	0	20	245	280	173	128	60	49	70	65	8	15	16	43	67	3.2

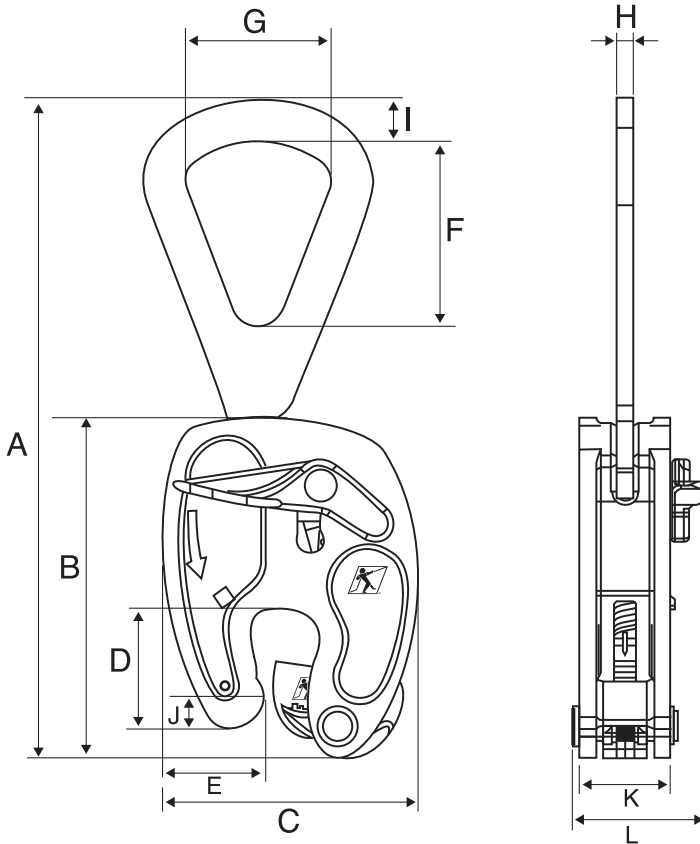

KSA

Trouble shooting chart

Item	Trouble	Cause	Solution	Remarks	Action
1	The clamp does not close freely.	The springs are damaged or missing. The cocking lever is deformed. The clip was sticking.	Yes	Check carefully that no other component of that lever is bent and rubbing in the clamp.	Return to a Tractel® authorized repair center
2	Wear of the cam teeth, or the cam shaft	It's normal to wear the teeth of the cam. The toothed cam must penetrate the material of the load being lifted.	Yes	The cam is a critical component to monitor. Always replace the cam shaft along with the cam.	Return to a Tractel® authorized repair center
3	Lifting Ring is deformed or damaged	Lifting Ring has been subject to drop or lifting in the wrong direction	No	Lifting Ring is damaged and can not be fixed	Clamp to be destroyed and replaced
4	Deformation of a component.	Very rare	Yes	The cam and cam shaft are critical components to be monitored.	Return to a Tractel® authorized repair center for inspection
5	The chain is broken or the cam is dislodged	Clamp has been overloaded	No	Such a rupture would only occur in case of overload.	Clamp to be destroyed and replaced
6	The cam is not in contact with the stop (for clamps that have a minimum opening of 0)	The springs are damaged or missing. The cocking lever is deformed.	Yes	Check carefully that no other component is damaged or the lever is bent and rubbing the clamp.	Return to a Tractel® authorized repair center for inspection
		The clamp is deformed	NO	Such deformation occurs only when overloaded.	Clamp to be destroyed and replaced
7	Clamp body deformed	Such deformation occurs only when overloaded	NO	Such deformation occurs only when overloaded.	Clamp to be destroyed and replaced



NK

Automatic Multiposition Plate Clamps

Description

Clamps fitted with a spring mechanism for a permanent contact of the cam onto the piece to be lifted, even when it is being put down. The NK has an automatic locking mechanism when the plate is correctly positioned at the back of the clamps throat.

The locking lever does not stick out so that the clamp may be used on the bare ground. The chain enables the revolving and makes the clamp's position easier. The cam is designed to mark only one side of the load.

NK Plate Clamp

Table 4

Ref.	Item Number	WLL lbs. (t) kg.	Opening		A*		B	C	D	E	F	G	H	I	J	K	L	Weight lb./kg.
			min	max	min	max												
NK1-0-20	50288	3300 (1.5)	0	3/4	17 1/8	18 1/2	7 9/32	4 23/32	1 3/16	5/16	2 3/4	2 11/16	4 1/8*	5/8	2 3/8*	11/32	3 1/4	8.80
		1 500	0	20	435	470	185	120	30	8	68	82.5	110*	16	60*	10.5	82	4
NK1-20-40	50298	3300 (1.5)	7/8	1 1/2	17 5/8	19 3/8	8 13/16	5 15/16	1 3/4	5/16	3 3/16	3 1/4	4 1/3*	5/8	2 3/8*	11/32	3 13/16	12.76
		1 500	20	40	448	493	224	151	44	8	81	82.6	110*	16	60*	10.6	97	5.8
NK1-40-60	50308	3300 (1.5)	1 5/8	2 5/16	18 1/4	20	9 25/32	6 3/4	1 3/4	5/16	3 3/4	3 1/4	4 1/3*	5/8	2 3/8*	11/32	4 13/32	13.2
		1 500	40	60	463	508	250	171	44	8	96	82.7	110*	16	60*	10.7	112	6
NK2-0-30	50318	6600 (3)	0	1 1/8	23 3/8	25 13/32	10 15/16	7 1/2	2 1/4	1/2	3 3/4	4 13/16	4 5/8	7/8	2 11/16	13/16	4 23/32	26.40
		3 000	0	30	594	645	278	190	58	13	95	122	117	22	68	20.5	120	12
NK2-30-60	50328	6600 (3)	1 3/16	2 5/16	23 15/16	26 1/6	12 3/16	8 1/4	2 1/2	1/2	4 7/16	4 13/16	4 5/8	7/8	2 11/16	13/16	5 19/32	33.0
		3 000	30	60	608	662	310	210	65	13	113	122	117	22	68	20.6	142	15
NK2-60-90	50338	6600 (3)	2 3/8	3 1/2	24 7/8	26 3/4		9 21/32	2 3/4	1/2	5	4 13/16	4 5/8	7/8	2 11/16	13/16	6 3/16	37.40
		3 000	60	90	631	680	338	245	70	13	128	122	117	22	68	20.7	157	17
NK3-0-40	50348	9900 (4.5)	0	1 1/2	25 3/8	28	14 1/4	9 27/32	2 19/32	1/2	5 5/16	5 1/2	4 5/8	7/8	2 11/16	13/16	6 7/16	55.0
		4 500	0	40	645	711	362	250	66	13	135	140	117	22	68	20.8	163	25
NK3-40-80	50358	9900 (4.5)	1 5/8	3	25 13/16	28 5/16	15 9/16	10 5/8	3 5/32	1/2	6 1/3	5 29/32	4 5/8	7/8	2 11/16	13/16	7 13/32	57.2
		4 500	40	80	655	719	395	270	80	13	160	150	117	22	68	20.9	188	26
NK3-80-120	50368	9900 (4.5)	3 3/16	4 5/8	27 7/16	29 15/16	14 5/8	12 1/4	3 1/4	1/2	7 3/32	5 29/32	4 1/2	7/8	2 19/32	25/32	8 3/16	59.4
		4 500	80	120	696	760	371	312	82	13	180	145	115	22	66	20.10	208	27
NK5-0-50	50378	16500 (7.5)	0	2	39 1/8	43 5/8	15 25/32	12 27/32	3 7/8	23/32	5 29/32	9 1/4	8 1/16	1 3/8	3 15/16	1	7 7/8	93.06
		7 500	0	50	993	1108	402	326	98	18	150	235	205	35	100	25	200	42.3
NK5-50-100	50388	16500 (7.5)	2	4	41 1/4	45 3/4	17 11/16	13	3 3/4	23/32	8 3/32	9 1/4	8 1/16	1 3/8	3 15/16	1	9 5/8	110.00
		7 500	50	100	1048	1162	449	330	95	18	205	235	205	35	100	25	244	50
NK5-100-150	50398	16500 (7.5)	4	6	42 1/2	46 3/4	18 11/16	15 9/16	4 1/8	23/32	9 1/16	9 1/4	8 1/16	1 3/8	3 15/16	1	10 1/2	132.00
		7 500	100	150	1080	1188	474	395	105	18	230	235	205	35	100	25	267	60

NK1 comes with round ring

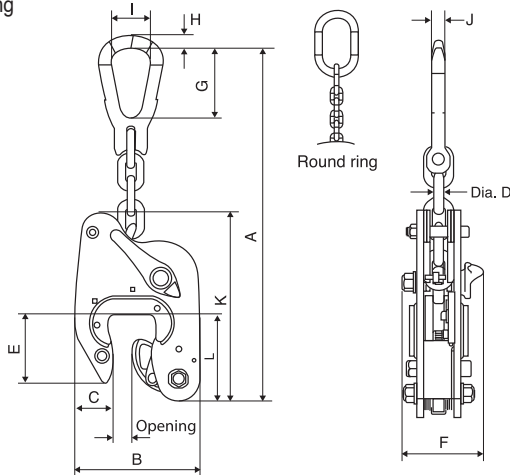

NK

Trouble shooting chart

Item	Trouble	Cause	Solution	Remarks	Action
1	The clamp does not close freely.	The springs are damaged or missing. The cocking lever is deformed. The clip was sticking.	Yes	Check carefully that no other component of that lever is bent and rubbing in the clamp.	Return to a Tractel® authorized repair center
2	The arming system of the clamp does not work (not blocking the opening of the clamp)	Fracture, deformation or failure of the arming system of the clamp (trigger)	Yes	According to the length of the clip, 2 fixes are available for NK1.	Return to a Tractel® authorized repair center
3	Wear of the cam teeth, or the cam shaft	It's normal to wear the teeth of the cam. The toothed cam must the load being lifted.	Yes	The cam is a critical component to monitor. Always replace the cam shaft along with the cam.	Return to a Tractel® authorized repair center
4	Chain Wear	This is normal wear mainly related to movement of the plate	Yes	All chain products should have an annual inspection.	Return to a Tractel® authorized repair center
5	Deformation of a component.	Very rare	Yes	The cam and cam shaft are critical components to be monitored.	Return to a Tractel® authorized repair center for inspection
6	The chain is broken or the cam is dislodged	Clamp has been overloaded	No	Such a rupture would only occur in case of overload.	Clamp to be destroyed and replaced
7	The cam is not in contact with the stop (for clamps that have a minimum opening of 0)	The springs are damaged or missing. The cocking lever is deformed.	Yes	Check carefully that no other component is damaged or the lever is bent and rubbing the clamp.	Return to a Tractel® authorized repair center for inspection
		The clamp is deformed	NO	Such deformation occurs only when overloaded.	Clamp to be destroyed and replaced
8	Clamp body deformed	Such deformation occurs only when overloaded	NO	Such deformation occurs only when overloaded.	Clamp to be destroyed and replaced



NX / NXR

Automatic Multiposition Non-marring Clamps

Description

Clamps fitted with jaws coated with polyurethane enabling one to lift and rotate loads without marring their surface. These products are equipped with a spring mechanism and an automatic grasping which

respectively permits a permanent contact of the cam onto the piece to be lifted, and ensures the clamp's closing when the plate is correctly positioned at the back of the clamp's throat. The chain enables the turning and makes the clamp's positioning easier.

NX Plate Clamp

Table 5

Ref.	Item Number	WLL lbs. (t) kg.	Opening		A		B	C	D	E	F		G	H	I	J	K	L	M	O	P	Chain Dia	Weight
			min	max	min	max					min	max											
NX05 0-20	50406	1100 (0.5)	0	13/16	6 3/4	8 11/16	8 3/16	3 1/4	1 15/16	4 1/8	14 13/16	18 1/8	1 5/8	2 13/16	1 5/8	1/2	7/16	3 1/8	2 3/4	X	5 5/16	3/4	9.9
		500	0	20	171	221	208	82	50	105	376	460	42	71	41	13	11	80	70	X	118	7	4.5
NXR05 0-100	50426	1100 (0.5)	0	4	7	12 1/8	8 3/16	3 1/4	2 5/16	4 1/8	14 15/16	18 3/8	2 5/16	2 13/16	1 5/8	1/2	7/16	3 1/8	2 3/4	13/16	5 5/16	3/4	13.2
		500	0	100	178	308	208	82	58	105	379	466	58	71	41	13	11	80	70	20	118	7	6
NXR05 20-120	50438	1100 (0.5)	13/16	4 1/4	8	12 7/8	8 3/16	3 1/4	2 5/16	4 1/8	14 15/16	17 9/16	2 5/16	2 13/16	1 5/8	1/2	7/16	3 1/8	2 3/4	13/16	5 5/16	3/4	12.8
		500	20	120	203	327	208	82	58	105	380	446	58	71	41	13	11	80	70	20	118	7	5.8
NXR05 40-140	50448	1100 (0.5)	1 9/16	5 1/2	8 3/4	13 11/16	8 3/16	3 1/4	2 5/16	4 1/8	15 1/16	18 1/16	2 5/16	2 13/16	1 5/8	1/2	7/16	3 1/8	2 3/4	13/16	5 5/16	3/4	13.2
		500	40	140	223	348	208	82	58	105	382	459	58	71	41	13	11	80	70	20	118	7	6
NX1.5 0-30	50418	3300 (1.5)	0	1 1/8	8 2/3	11 1/4	10 3/16	4 3/16	2 11/16	4 3/4	20	24	2 3/16	3 7/16	1 15/16	1/2	5/8	3 15/16	3 1/2	X	5 7/16	13/32	24
		1 500	0	30	220	285	256	104	68	120	508	610	56	87	49	13	16	100	90	X	145	10	11

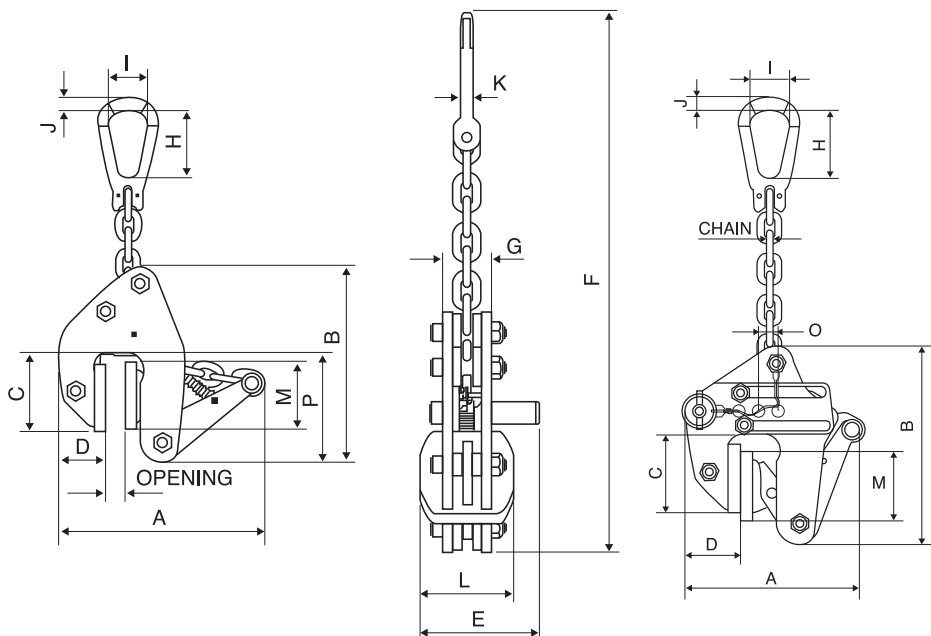

NX / NXR

Trouble shooting chart

Item	Trouble	Cause	Solution	Remarks	Action
1	The clamp does not close freely.	The springs are damaged or missing. The cocking lever is deformed. The clamp is sticking.	Yes	Check carefully that no other component is damaged. Lever is bent and rubbing on the clamp.	Return to a Tractel® authorized repair center
2	The arming system of the clamp does not work (not blocking the opening of the clamp)	Fracture, deformation or failure of the arming system of the clamp (trigger)	Yes	Clamp need to be repaired.	Return to a Tractel® authorized repair center
3 NXR model only	The adjustable locking pin is no longer working	Locking pin is bent or damaged	Yes	New part required	Return to a Tractel® authorized repair center
		The flanges of the clamp are deformed (the holes do not match or are distorted).	No	Such deformation occurs only when overloaded.	Clamp to be destroyed and replaced
4	Wear of the polyurethane on the pads	Check the wear of the polyurethane coating to ensure a good grip on the load.	Yes	The polyurethane coating is critical to be monitored. When loads start to slip the pads need replacing. Degreasing is recommended regular and systematic.	Return to a Tractel® authorized repair center
5	Deformation of a component.	This is normal wear mainly related to link to link wear for the plate turning	Yes	All chain products should have an annual inspection	Return to a Tractel® authorized repair center
6	Poor condition of the hardware	Very Rare	Yes	Wear with possible constraints when lifting.	Return to a Tractel® authorized repair center
7	Broken chain	Clamp overloaded	No	Such a rupture would occur in case of overload	Clamp to be destroyed and replaced
8	Pin for the lifting ring is broken	Clamp been dropped	Yes	Do not use until a new approved pin is obtained	Return to a Tractel® authorized repair center
9	Failure of the pads to close	The springs are damaged or missing. The cocking lever is deformed.	Yes	Check carefully that no component is deformed and rubbing in the clamp	Return to a Tractel® authorized repair center
		The clamp is deformed	NO	Such deformation occurs only when overloaded.	Clamp to be destroyed and replaced
10	Wear at the joints of the assembly hardware	Normal wear during use	Yes	Placement hardware required	Return to a Tractel® authorized repair center



KS / KSA / NK

Use and Installation

Clamps for lifting of steel plates, sections, welded-plated assemblies, and structural steel.

These clamps are fitted with a spring mechanism ensuring permanent contact of the cam against the piece to be lifted.

NK: this model is fitted with an automatic gripping mechanism to clamp the plate when it is correctly positioned, i.e. fully seated into the throat of the clamp.

- 1) Open the clamp by pushing the red locking lever (5/7) down ; **KS** and **KSA** until the trigger is activated by locking it on the cleat. **NK:** until the trigger (8) is activated.
- 2) Fit the clamp onto the piece to be lifted, push it home so that the throat is in contact with the edge. Make sure the piece is fully seated.
- 3) **KS** and **KSA:** release the lever: the safety spring is now activated, the cam (4) is locked against the piece to be lifted.

NK: the trigger (8) is released, the cam (6) comes into contact with the plate, the red locking lever (7) goes up: the clamp is now engaged.

- 4) The piece can be lifted as it is clamped by the force of the weight.
- 5) Once the piece is moved and laid down, release the clamp by opening it via the red locking lever (5/7).

WARNING



NOTE: concerning **KS1 t, 2 t and 3 t** models: The clamp may be held open by pushing the red lever against the body of the clamp, until the retainer pin on the lever (5) is activated in its housing on the flange (16). To release, pull the lever slightly outwards so as to bring the lever pin out of its housing in the flange.

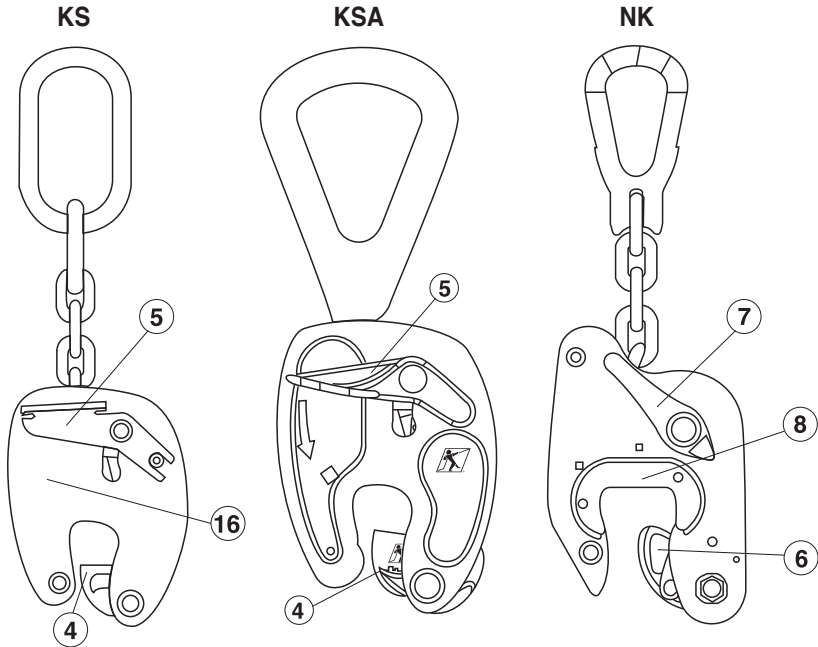

KSA Applications

Lifting of plates, iron beams, welded parts, steel frames

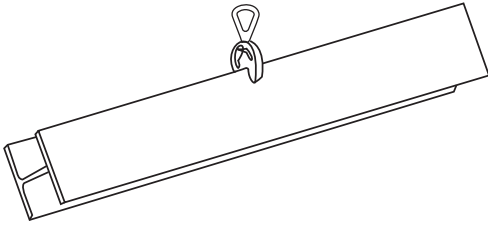

Lifting function: always work on the axle of the clamp (Fig. 1) and never exceed the allowable 15° angle of the ring (Fig. 2).

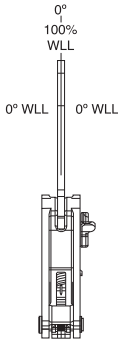

Fig. 1

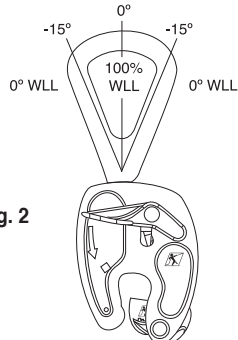

Fig. 2

Lifting of loads in a vertical position with 2 clamps and no lifting beam: do not exceed the 30° sling angle and ensure the clamps are in line with the slings (Fig. 3).

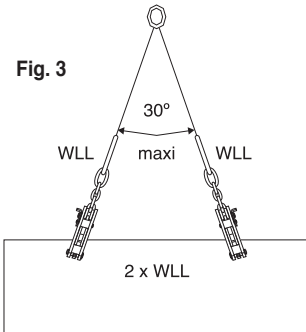
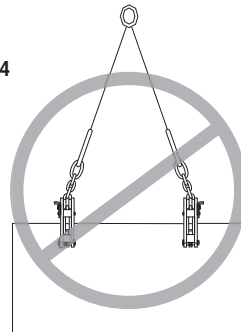

Fig. 3

Fig. 4



Tilting or lifting of loads in a horizontal position is PROHIBITED. Use KS or NK clamps with chain for these applications (Fig. 4).



⚠ WARNING

KS, KSA and NK Important Instructions

- Never Use on fragile loads. (For fragile items us the **NX** series clamp)
- Never use for personnel lifting Strictly forbidden to walk or be under the load.
- Never exceed the working load limit.
- Using this clamp marks the load. (For non-marking use the **NX** series clamp)
- The plate or piece to be lifted must always be driven home into the throat of the clamp.
- Surface hardness of pieces to be lifted: maxi. 300 Brinell (**KS**) / 330 Brinell (**NK**) and minimum 29,000 PSI tensile strength (20 daN/mm²).
- Some stainless steels are particularly abrasive. Inspect for wear of teeth of the cam in this case.
- When not in use, ensure clamps are always unlocked (cam closed).
- Never lift more than one plate at a time.
- Apply the downgradation if necessary (see sketch).
- The minimum weight of lifting load should be equal to 5% of the clamp's WLL (e.g. if clamps

WLL is 1 ton, then minimum weight is 100 lbs.). This value is given for a clamp in new working order and respecting Tractel® Inc. conditions of use and recommendations. Consult Tractel® in case of loads with weight less than the minimum recommended value.

- Lifting clamps are not suitable for creating permanent joints. Working temperature: -20° to +100°C. (-10° to +212°F)

⚠ WARNING

After an intensive period of use, the chain or ring may show signs of elongation, wear, or other damage which could cause the chain or ring to break. It is therefore recommended that the lifting chain is inspected regularly Corroded or cracked links, distorted or twisted links, worn or stretched links require that the unit be taken out of service until replaced. A written inspection log should be maintained.

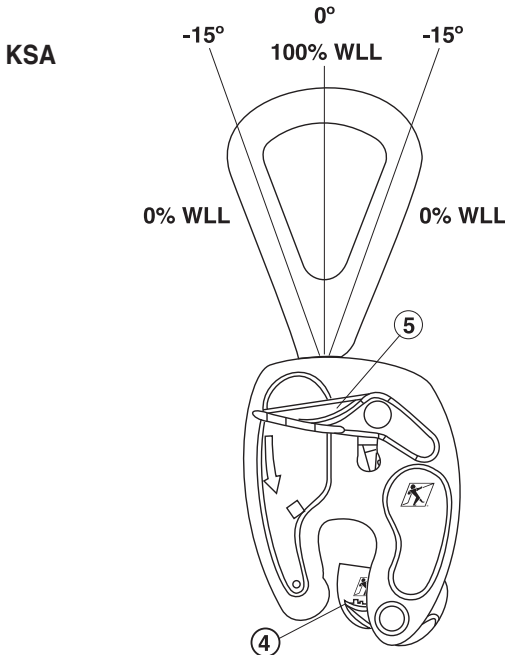

KS / NK

Applications

Lifting and revolving of plates, profiles, fabricated assemblies, steel frames

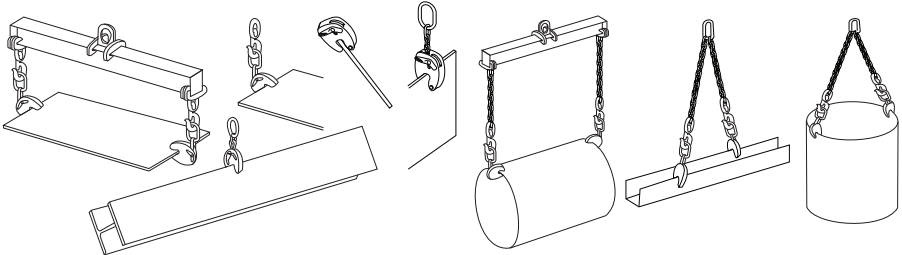

Lifting function: do not exceed the allowable 15° angle between the chain and the flanges' plane.

Turning function: for this application, the clamp's working load limit is divided by 2.

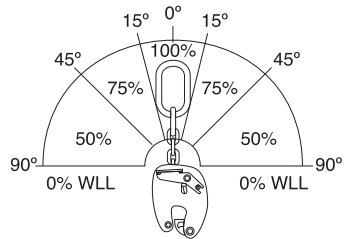
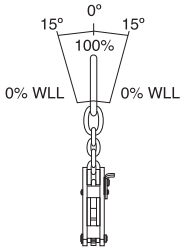

Function lifting of loads in a vertical position with 2 clamps and no lifting beam: do not exceed the 30° sling angle.

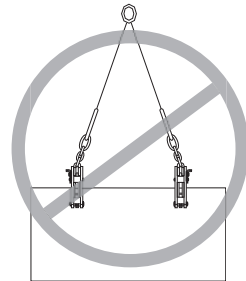
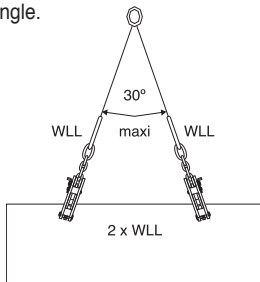

Function lifting of loads in a horizontal position using 2 clamps at least and a lifting beam: the working load limit of each clamp is divided by 2.

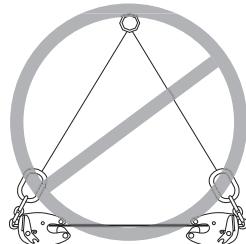
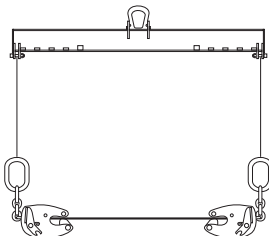

www.tractel.com

NX / NXR

Use and Installation

Clamp for lifting and turning without marking the surface of smooth or polished pieces (stainless steel, aluminium, pre-lacquered, laminated wood, concrete, stone, plastic, glass plates, welded-plate assemblies, etc...).

This clamp is fitted with an automatic gripping mechanism: the locking handle is designed to fit the clamp over the edge of the object to be moved and the automatic locking on the trigger grips the piece to be lifted.

It is also fitted with a spring mechanism ensuring permanent contact of the cam against the piece to be lifted, even when it is laid down.

The NXR models feature adjustable jaws that are adjustable by means of a pin in increments of 20 mm.



For Fragile pieces: Use the manual opening and locking on the handle without bringing it to its limit stop (trigger not activated).

NX instructions

- 1) Open the clamp by pushing the red handle (10) down until the trigger (8) is activated. Do not activate the trigger when handling fragile loads.

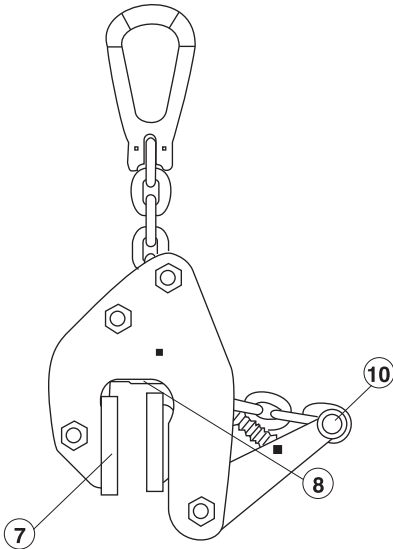

- 2) Fit the clamp onto the piece to be lifted, push it home so that the throat is in contact with the edge of the piece.
- 3) The trigger (8) is released, the jaws (7) come into contact with the piece to be lifted, the red handle (10) goes up: the safety mechanism is now activated and the clamp is ready to lift.
- 4) The piece can be lifted as it is clamped by the force of the weight.
- 5) Once the piece has been moved and laid down, release the clamp by opening it via the red handle (10).

NXR Instructions

Before performing operations 1 to 5 in the NX instruction above complete the instructions below.

- A) To adjust the opening of the clamp, remove the pin (18).
 - B) Slide the mobile flanges (4) over the fixed flanges (3) to the desired opening.
 - C) Put the pin (18) back a secure in place
- See NX instruction 1-5 above.

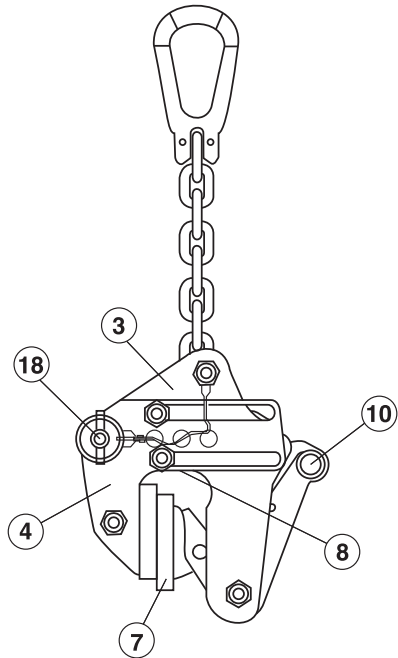

⚠ WARNING

NX Important instructions

- This clamp can also be used for hardened steels.
- The plate or piece to be lifted must always be driven home into the throat of the clamp.
- No limit regarding surface hardness of loads to be lifted.
- Never use on greasy or oily pieces.
- Do not use the automatic grasping mechanism on fragile loads.
- To avoid injury, ensure the clamps are always unlocked when not in use (closed jaws).
- The minimum weight of lifting load should be

- equal to 5% of the clamp's WLL (e.g. if clamps WLL is 1 ton, then minimum weight is 100 lbs.). This value is given for a clamp in new working order and respecting Tractel® Inc. conditions of use and recommendations. Consult Tractel® in case of loads with weight less than the minimum recommended value.
- Lifting clamps are not suitable for creating permanent joints.
 - Never lift more than one plate at a time.
 - Apply the downgradation if necessary
 - Working temperature: -20° to +80°C (4° to 176°F).

NX - Examples of lifting applications see page 15
NX - Lifting details see page 15

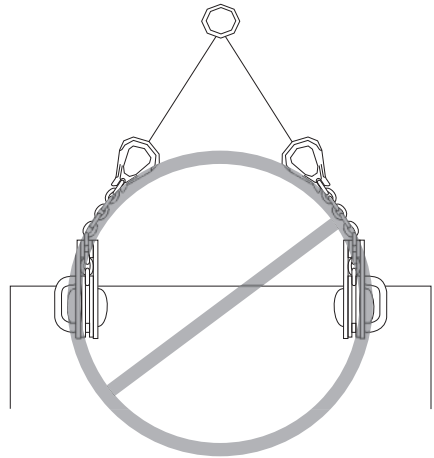
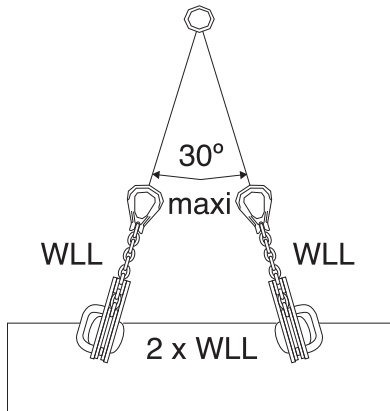

NX

Applications

Lifting and revolving without marring of smooth or polished pieces such as stainless steel plates, aluminium, pre-lacquered plates, wood, laminated sheets, marble, concrete, glass, plastic

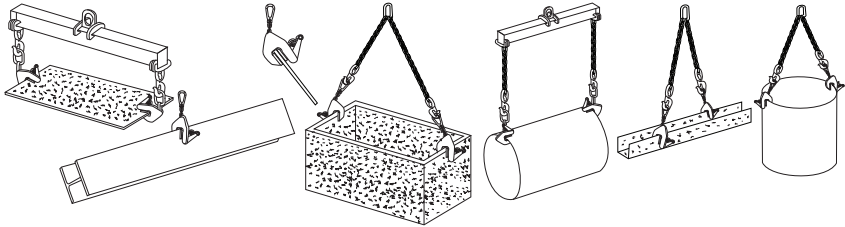

Lifting function: do not exceed the allowable 15° angle between the chain and the flanges' plane.

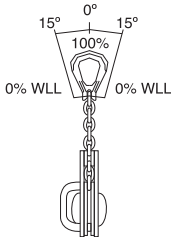

Turning function: for this application, the clamp's working load limit is divided by 2.

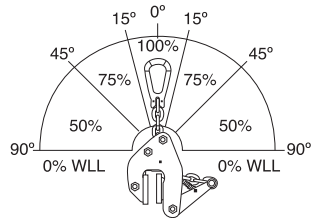

Function lifting of loads in a vertical position with 2 clamps and no lifting beam: do not exceed the 30° sling angle.

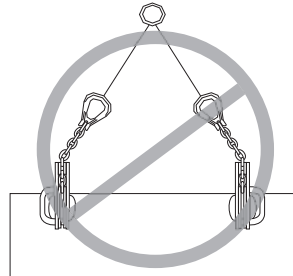
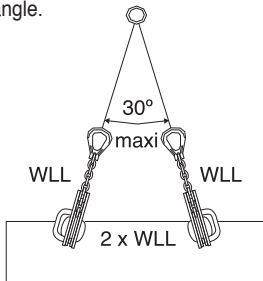

Function lifting of loads in a horizontal position using 2 clamps at least and a lifting beam: the working load limit of each clamp is divided by 2.

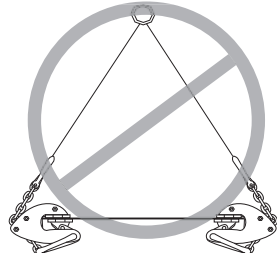
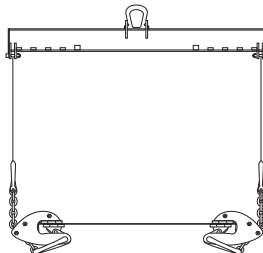

General Maintenance

General maintenance

- Remove all dirt and foreign matter.
- Lubricate all moving parts regularly with machine oil
- Inspect weekly or monthly depending on frequency of use
- Check for jaw wear, chain wear or damage, ring wear, or cam damage.
- Check for elongation of springs, bolts, pins, rings, chain links
- Inspect welds for cracks
- Check that hardware and fasteners are secure

If there is any question of safety remove from service and contact Tractel for repair.



WARNING

After an intensive period of use, the chain or ring may show signs of elongation, wear, or other damage which could cause the chain or ring to break. It is therefore recommended that the lifting chain is inspected regularly Corroded or cracked links, distorted or twisted links, worn or stretched links require that the unit be taken out of service until replaced. A written inspection log should be maintained.

Labels

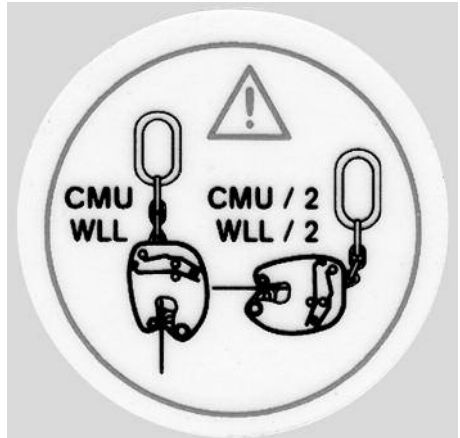
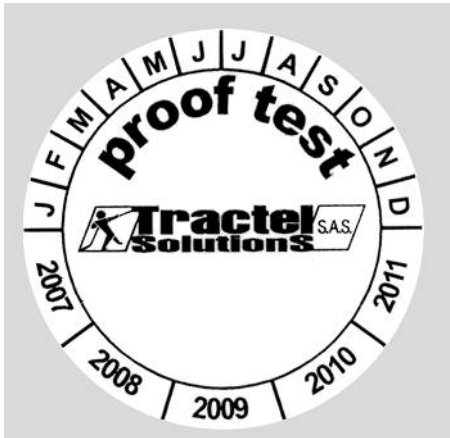

⚠ WARNING

- Do not exceed the rated load WLL
- Do not use a damaged or malfunctioning unit
- Do not use a unit with missing parts
- Do not lift people or loads over people
- Do not leave a suspended load unattended
- Do not remove or obscure warning labels
- Stay clear of load
- Do not lift loads higher than necessary
- Do not alter or modify the product
- Do not operate before reading and understanding the operators manual

⚠ WARNING

Before use, read and understand operators manual - serious injury may result with improper use.



www.tractel.com

Contact Us At:

Tractel® Inc. - U.S.A

**Griphoist Division
51 Morgan Drive
Norwood, MA 02062
Tel: (781) 401-3288
Toll Free: 1-800-421-0246
Fax: (781) 828-7600**

Tractel® Inc. - U.S.A

**365 Cloverleaf Drive, Unit D
Baldwin Park, CA 91706
Tel: (626) 937-6727
Fax: (626) 937-6730**

Tractel® Ltd. - Canada

**Griphoist Division
11020 Mirabeau
Anjou, Quebec H1J 2S3
Tel: (514) 493-3332
Toll Free: 1-800-561-3229
Fax: (514) 493-3342**

sales@tractel.com www.tractel.com

As we are dedicated to continuous improvement of our products, the Tractel® Group reserves the right to modify the specifications of the equipment described in this manual. As a result, illustrations may not represent exactly the product you receive: components and/or design may differ.



www.tractel.com